



THE GENERAL RADIO

Experimenter



- 9.5 - 22MHz
- 22 - 48MHz
- 48 - 108MHz
- 108 - 220MHz
- 220 - 420MHz
- 400 - 500MHz

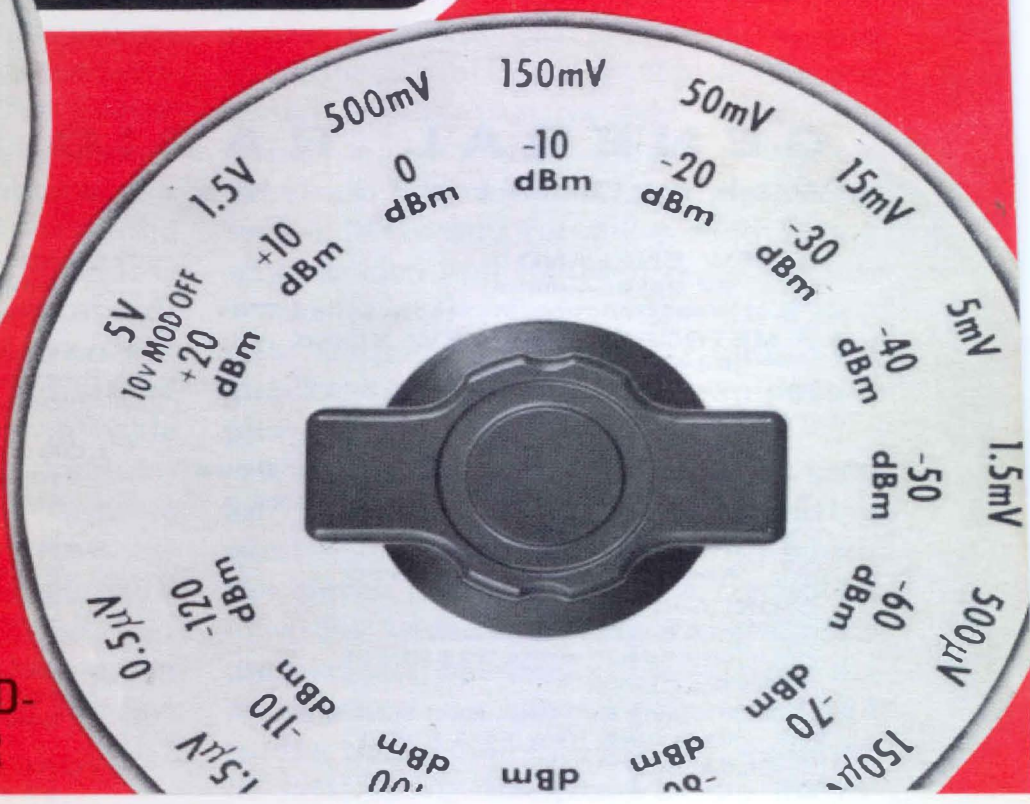

NEW
500-MHz STANDARD-SIGNAL GENERATOR

VOLUME 41 · NUMBER 3 / MARCH 1967

the Experimenter

© 1967 — General Radio Company, West Concord, Mass., USA

Published monthly by the General Radio Company

THIS ISSUE

| | Page |
|--|------|
| A New 500-MHz Standard-Signal Generator..... | 3 |
| The Guillotine Capacitor..... | 17 |
| New GR874 Terminations..... | 19 |

GENERAL RADIO COMPANY

West Concord, Massachusetts 01781

* **NEW ENGLAND**
 22 Baker Avenue
 West Concord, Massachusetts 01781

* **METROPOLITAN NEW YORK**
 845 Broad Avenue
 Ridgefield, New Jersey 07657

PHILADELPHIA
 Fort Washington Industrial Park
 Fort Washington, Pennsylvania 19034

* **WASHINGTON and BALTIMORE**
 Post Office Box 1160
 11420 Rockville Pike
 Rockville, Maryland 20850

ORLANDO
 113 East Colonial Drive
 Orlando, Florida 32801

SYRACUSE
 Pickard Building, East Molloy Rd.
 Syracuse, New York 13211

CLEVELAND
 5579 Pearl Road
 Cleveland, Ohio 44129

* **CHICAGO**
 9440 W. Foster Avenue
 Chicago, Illinois 60656

* **DALLAS**
 2600 Stemmons Freeway, Suite 210
 Dallas, Texas 75207

* **LOS ANGELES**
 1000 North Seward Street
 Los Angeles, California 90038

SAN FRANCISCO
 Post Office Box 1389
 626 San Antonio Road
 Mountain View, California 94040

MONTREAL
 1255 Laird Boulevard
 Town of Mt. Royal, Quebec, Canada

* **TORONTO**
 99 Floral Parkway
 Toronto 15, Ontario, Canada

* Repair services are available at these offices

GENERAL RADIO COMPANY (OVERSEAS), 8008 Zurich, Switzerland

GENERAL RADIO COMPANY (U.K.) LIMITED, Bourne End, Buckinghamshire, England

REPRESENTATIVES IN PRINCIPAL OVERSEAS COUNTRIES

A NEW 500-MHz STANDARD-SIGNAL GENERATOR

A great many interacting problems surround the development of a standard-signal generator, and the final instrument usually combines a few successes with more than a few compromises. If the signal generator is to have an output-level range of 160 dB, accurate frequency control without trimmers, and leveling in all modulation modes, the challenges are compounded. Yet these were among the design objectives of GR's latest signal-generator development. A major engineering effort turned the problems into successes and produced the high-performance standard-signal generator introduced in this month's feature.

The basic tool for the alignment and testing of receivers, filters, amplifiers, and attenuators is the a-m standard-signal generator. The term "standard-signal" means that all primary characteristics are calibrated, and it implies signal quality beyond that expected of the ordinary signal source. Thus, it is generally accepted that an a-m standard-signal generator shall have calibrated output frequency, calibrated output level adjustable over a wide range, and calibrated depth of modulation. As technology has evolved, users have demanded increasingly wide ranges of these characteristics, along with major reductions of incidental and spurious effects; at the same time, speed and convenience of use have become prime concerns.

A NEW STANDARD OF PERFORMANCE

General Radio's new TYPE 1026 Standard-Signal Generator meets this

growing demand for higher performance and simple operation. Over a frequency range from 9.5 to 500 MHz, the 1026 delivers one-half watt of leveled cw power to a 50-ohm load, approximately 100 times the power previously available from a well shielded signal generator. Modulation characteristics are equally impressive. At all carrier frequencies, 95% modulation is available for outputs up to 5 volts behind 50 ohms (compared with up to 10 volts behind 50 ohms for cw operation). At 50% 1-kHz amplitude modulation, incidental fm is less than 1 part per million, an order of magnitude improvement over previous designs, and envelope distortion for the 1-kHz internal modulation is less than 1%. Other unique a-m features include provision for wide-band modulation up to 1.5 MHz and for pulse modulation with leveled and metered peak output.

Electrical fine frequency control permits frequency modulation and, with auxiliary synchronizing equipment, phase-locked operation.

The three front-panel elements used for this month's cover illustration symbolize the extreme ease with which the signal generator can be controlled over its wide operating ranges. The user selects frequency by setting the band switch to the proper range and tuning the frequency control. The large, back-lit drum dial provides an unambiguous readout accurate to 0.5%. There are no secondary frequency controls, no trimmers to peak. Output

level is set by a precision step attenuator supplemented by a continuous carrier level control; the meter and large attenuator dial provide a highly legible readout. A flick of the wrist takes the user from 0.1 microvolt to 10 volts behind 50 ohms, without external amplifiers and their attendant tuning, shielding, and level-monitoring problems.

RELATION TO OTHER SIGNAL SOURCES

The characteristics of the standard-signal generator, as embodied in the 1026, set it distinctly apart from such relatively simple signal sources as GR's general-purpose oscillators on the one hand and from our highly sophisticated decade-frequency-synthesizer line on the other. The oscillators are ideal for antenna and bridge measurements and as local oscillators for heterodyne detectors, but they lack the output-level calibration, ultra-high shielding, isolation of frequency from load pulling effects, and calibrated modulation characteristics required for receiver tests and for precision insertion-loss measurements.

Frequency synthesizers are quite complex instruments in which the primary concern is to generate precisely known output frequencies, usually with relatively less attention devoted to achieving a wide range of accurately calibrated output levels and to modulation capabilities. Furthermore, the spectral impurities found in the output of frequency synthesizers are generally of a different character from those in the output of the free-running, continuously tunable LC oscillator used in the 1026. The unwanted outputs of the latter are almost entirely harmonics or hum sidebands close to the carrier;

other discrete spurious outputs are not present, and broadband noise sidebands are of extremely low amplitude.

Thus a good conventional a-m standard-signal generator is preferable to a synthesizer for certain important classes of measurements, including receiver spurious-response tests, receiver sensitivity checks, which require accurately known low-level signal amplitudes and known modulation characteristics, and measurements of receiver selectivity, filter cutoff, and attenuator insertion loss, all of which require a wide range of accurately calibrated output levels.

APPLICATIONS

The 9.5-to-500-MHz frequency range of the 1026 includes the important vhf and uhf aircraft communications bands, which use double-sideband a-m, and most of the common high i-f bands. Obvious applications thus lie in the alignment and testing of receivers, filters, amplifiers, attenuators, and other devices used in such service.

The largest single application area for standard-signal generators is receiver testing. The 1026 is ideal for receiver testing because of its high, leveled output, single-dial tuning, and low modulation distortion.

AGC and Squelch Testing

The receiver manufacturer is usually called upon to specify the range of rf input voltage over which the AGC will maintain a relatively constant audio output level. For such tests, the 1026 offers a wide range of output levels, extremely low incidental fm, and a highly accurate output attenuator.

The wide-band- and pulse-modulation modes are also useful for precise

checks of squelch and AGC recovery time.

Distortion Tests

The maximum nonlinear distortion in a receiver is generally specified at about 5 to 10%. Any envelope distortion in the signal generator will, of course, introduce error in the measurement. Negative envelope feedback and adequate buffering (which virtually eliminates incidental fm) reduce distortion in the 1026 to 1% at 50% a-m and to less than 3% at the critical 80% a-m level. Not only is the 1026 output leveled, but there is no peaking by the operator to obtain specified modulation performance.

Sensitivity Tests

In measurements of receiver sensitivity, a signal generator must produce an rf signal at a low, accurately known level, with known modulation percentage. It is important to keep these characteristics, as well as carrier frequency, constant during the test procedure. In the 1026, the output attenuator is accurate to ± 0.1 dB per step, with a maximum accumulated error of ± 0.5 dB. Rf leakage is negligible even when the output is in tenths of a microvolt. After warmup, the output level will remain constant to ± 0.01 dB over any 15-minute period, even with $\pm 10\%$ line-voltage fluctuations.

Signal-to-Noise Ratio

In measurements of signal-to-noise ratio, the usual procedure is to compare the receiver audio output when a modulated carrier is applied with the output without modulation. Any spurious modulation due to hum or noise

will appear as additional receiver noise. The very low residual a-m hum and noise of the 1026 (at least 70 dB below carrier) permit measurements of signal-to-noise ratios up to 60 dB with confidence.

Other Receiver Tests

Measurements of adjacent-channel rejection, image-frequency rejection, and responses due to local-oscillator harmonics can all be made with greater confidence and convenience, because of the purity and stability of the 1026 output.

Noise-limiter effectiveness is commonly measured by tests on the receiver's ability to limit the noise spikes to some specified modulation percentage, such as 80%. Thus the ability of the 1026 to provide accurate high-percentage modulation makes it particularly attractive for noise-limiter testing.

Amplifier, Attenuator, Filter Tests

In tests of amplifier gain, frequency response, and distortion, the leveled output of the 1026 eliminates re-peaking of controls as frequency is changed. Also, the high output levels available from the 1026 will drive i-f amplifiers and low-impedance stages directly, without the addition of power amplifiers. Pulse response of i-f amplifiers in the 30-to-200-MHz range is of great interest because of the widespread use of such amplifiers in radar systems. The clean leveled pulse performance of the 1026 speeds up measurements on this class of equipment considerably.

In filter-response tests, the high output capability of the 1026 is especially useful when the rejection outside the pass band is 70 dB or more, since

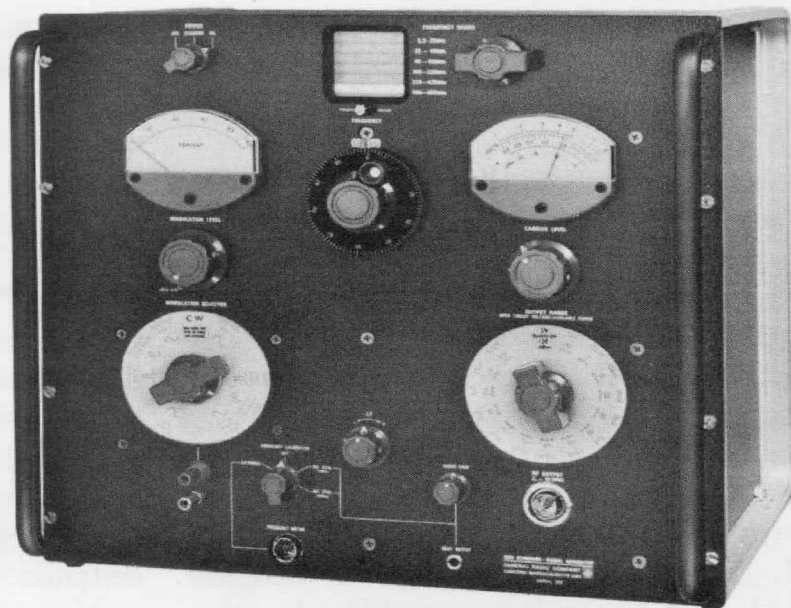

Figure 1. The 1026 Standard-Signal Generator.

the filter output signal will still be easily detectable by an untuned high-frequency voltmeter. The high-level output, automatic leveling, and low leakage are valuable in attenuator testing. Phase-lock stabilization of carrier frequency (with auxiliary synchronizing equipment) also permits the use of highly selective detectors to improve signal-to-noise ratios in measurements of insertion loss in excess of 100 dB.

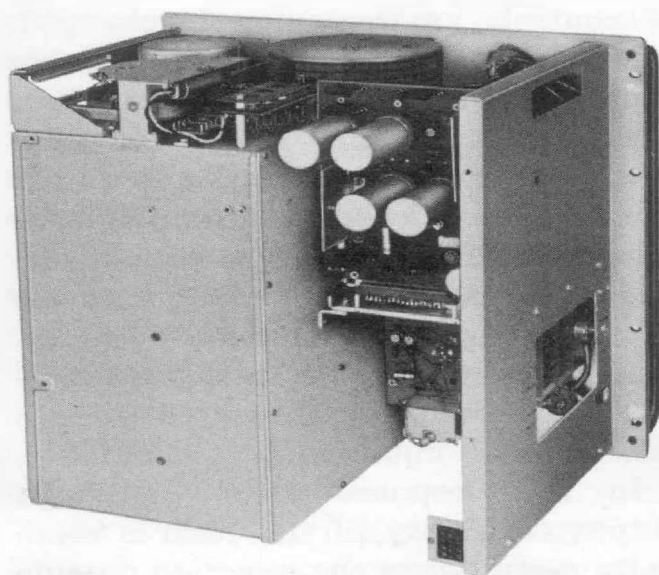

Figure 2. Rear interior view.

GENERAL DESCRIPTION

The 1026 Standard-Signal Generator (Figure 1) is basically a continuously tunable master oscillator-power amplifier chain, with appropriate power supply and modulator circuits to permit automatic level control under a wide range of modulation conditions.

The instrument is built in three main subassemblies: rf assembly, modulator assembly, and power-supply assembly (see Figure 2). Each subassembly is extensively pretested before being secured to the panel assembly, which supports all controls and which provides interunit cabling.

Vacuum tubes are used in the rf stages because of their superior performance and reproducibility in the upper part of the frequency range, but all components in the modulator and power supply are solid-state.

The 9.5-to-500-MHz frequency range is covered in six bands, five of which cover approximately an octave each. The bands were selected so that important allocations, such as the 88-to-108-MHz fm band, the 108-to-156-MHz vhf

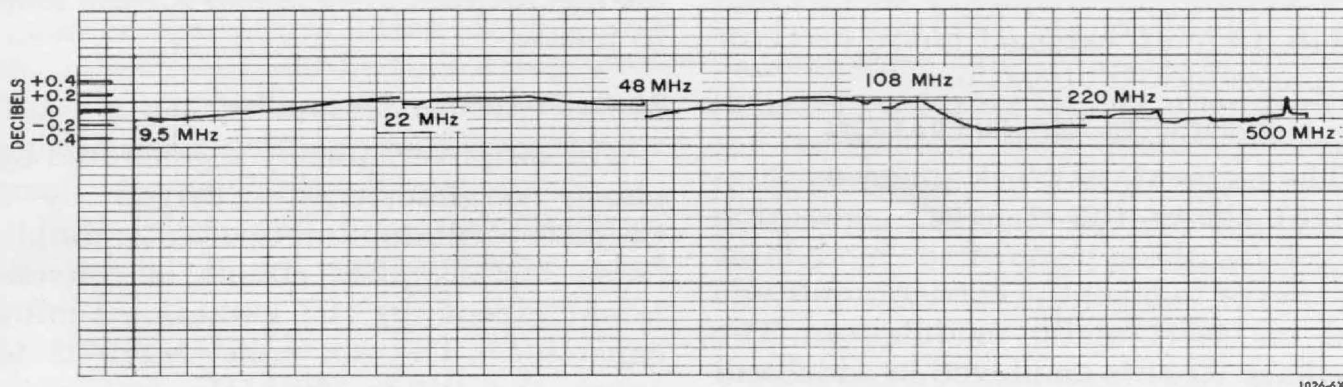

Figure 3. Output level vs carrier frequency. The small discontinuities in level (typically less than 0.2 dB) occur at frequencies where the range is changed.

aircraft band, and the 225-to-406-MHz uhf aircraft communications band, each lie entirely within a single range.

Once the appropriate band has been selected, frequency is controlled by a single dial, the amplifier trimmer control thus passing into history. The output is adjustable from 0.1 microvolt to 10 volts behind 50 ohms, and the shielding challenge implied by such a range of levels has been met.

Highly effective leveling keeps the output constant in the face of changes in frequency or load impedance (Figure 3). The leveling loop is used for envelope feedback for internal or external audio modulation, giving very low modulation distortion. Leveling is also in effect with wide-band externally applied modulation frequencies up to as high as 1.5 MHz, depending on carrier frequency, and with pulse modulation. The use of two buffer stages between oscillator and modulated power amplifier results in unusually low incidental fm in the presence of high-level amplitude modulation. The resulting excellent sideband symmetry is shown in Figure 4.

For added flexibility, the signal generator includes an internal crystal calibrator, a high-level auxiliary output,

and provision for electrical fine frequency control for fm or phase-lock operation. The auxiliary output is unusually versatile: It can be used to drive an external counter for monitoring the signal-generator frequency at the same time that a low-level output from the main rf output connection is delivered to a receiver under test; it can be disabled with better than 100-dB isolation by means of an internal coaxial switch, thereby eliminating possible leakage from connected apparatus or cables; it can serve as an input, permitting the signal generator to be used

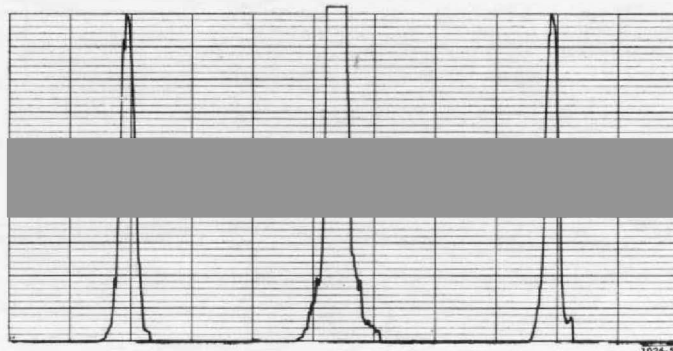

Figure 4. Extreme symmetry of 1-kHz sidebands at 50% modulation is evidence of very low incidental fm. Carrier amplitude (center spike) is offscale because of expansion to show sidebands.

as a heterodyne frequency meter; and it can drive an external phase detector for phase-locked operation.

PRINCIPLES OF OPERATION

The elementary block diagram (Figure 5) shows the rf power-generating stages and those parts of the modulator that serve to level the carrier amplitude and to insert audio modulation. The ancillary circuits employed in wideband and pulse modes of modulation have been omitted from this simplified diagram.

The output stage of the rf power generator and the modulator stages form a negative-feedback loop. Since the loop encloses a signal detector, it is the carrier amplitude or envelope that is fed back rather than the radio-frequency wave itself. The reference against which this loop stabilizes itself is a dc voltage supplied by the CARRIER LEVEL control potentiometer. Modulation voltages can be superposed on this reference, thus forcing the loop to follow an audio-frequency input. Special provisions are made to accommodate wide-band- and pulse-modulat-

ing signals that are too fast for the loop to follow.

Radio-Frequency Generation

The output frequency is generated by planar ceramic triodes driven by a Colpitts oscillator and two buffer amplifiers. The Colpitts circuit is conventional except for the guillotine tuning capacitor.¹ The six coils required to cover the 9.5-to-500-MHz frequency range are mounted on a turret that rotates with band changes.

The three lowest frequency ranges cover tuning ratios of $2\frac{1}{3}$ to 1, with some overlap between ranges. The plates of the guillotine tuning capacitor are shaped so that frequency varies linearly with dial rotation on these ranges, simplifying interpolation in bandwidth measurements on high-frequency i-f amplifiers and filters. The upper three ranges become progressively narrower in coverage in order to maintain satisfactory interstage tracking and adequate drive levels.

A small amount of electronic tuning is possible through control of the bias on a varactor diode. Owing to the

¹ See "The Guillotine Capacitor," p 17, this issue.

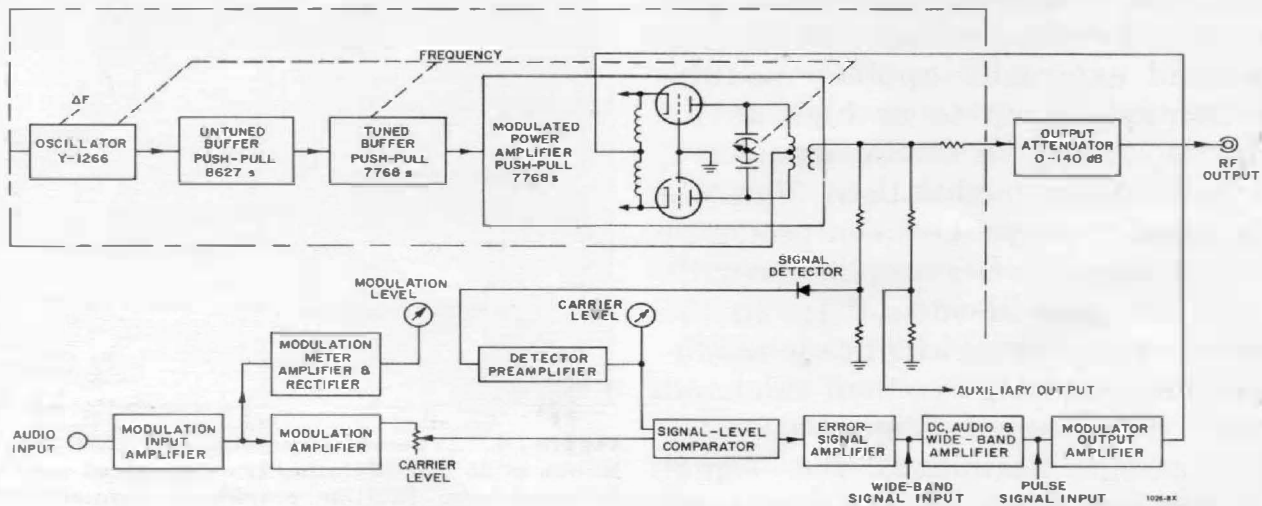

Figure 5. Elementary block diagram.

large signal level at which this diode operates, current is being drawn, and the consequent self-biasing action produces a nearly linear frequency-vs-applied-control-voltage characteristic for small frequency deviations.

Both plate and heater voltages of the oscillator are electronically regulated for minimum residual fm and for maximum stability against line-voltage changes.

The output of the oscillator drives a pair of nuvistor power triodes in a push-pull grounded-grid broadband amplifier stage, which operates at approximately unity gain. This stage effectively isolates the oscillator from reaction due to modulation of the output stage. The untuned buffer in turn drives a push-pull tuned buffer consisting of a pair of high-performance ceramic planar triodes. The tuning capacitor, a second guillotine, and the coil turret are almost identical to those used in the oscillator. This tuned buffer gives the power gain needed to drive the modulated output amplifier.

The modulated output amplifier is almost identical to the tuned buffer. The same tube types are employed, the guillotine tuning capacitor is identical, and the coil turret is similar. The most significant difference is that bias is controlled by the modulator, which is in series with the cathode ground return.

Careful control of the tuned-circuit elements ensures good tracking between stages without front-panel trimmers. Minor detunings, resulting from the inevitable differences in configuration between oscillator and amplifier stages, are controlled to produce similar effects. For example, coil trimming capacitors used on the top two frequency ranges

are nominally identical, but they are nevertheless reset automatically by the band-change mechanism to values established during factory alignment of the instrument. High-quality precision gears and tight control of runout in the common drive shaft are also important factors in achieving a tracking accuracy that is typically 0.1% in frequency.

Instrument structure has a first-order effect on the stability, reproducibility, and shielding integrity of a signal generator. The radio-frequency portion of the 1026 is built in a single large casting, with separate pockets for the individual stages (Figure 6). Power and modulation leads are brought in through appropriate low-pass filters, shafts are brought out insulated through wave-guide-below-cutoff pipes, and

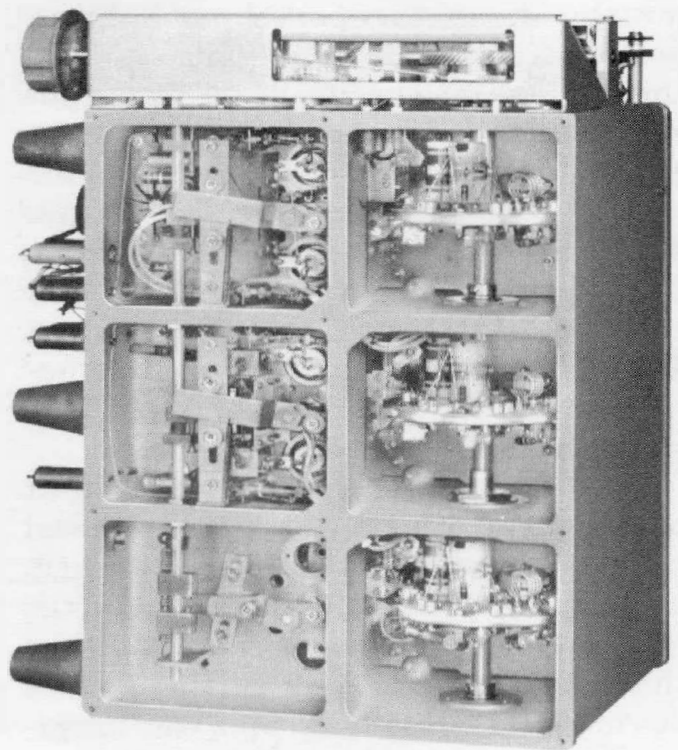

Figure 6. Side interior view. The ganged turrets for the three tuned stages are in the right-hand compartments; the tube sockets for the amplifier and tuned buffer stages are visible in the upper two left-hand compartments.

shield covers have multiple fingers for good contact, with double rows of fingers in selected "hot" locations. The casting supports the individual guillotine tuning capacitors and the precision gear drive that couples them to the front-panel FREQUENCY control. All adjustments and tubes are accessible without major disassembly in case of need for servicing.

Output System

The output of the modulated power amplifier is detected by a crystal diode, whose dc output is amplified and used to drive the CARRIER LEVEL meter. The detected output also serves as the input signal to the feedback-leveling amplifier. The diode is fed from a compensated voltage divider, which reduces the rf level to match the diode ratings yet still keeps it high enough for the diode to operate as a linear peak detector. The divider also isolates the diode somewhat from the rf output and thus reduces the distortion of the carrier by the diode. The automatic leveling makes a zero-impedance Thévenin generator at the driving point for the divider. A 50-ohm resistor between this point and the output attenuator establishes the source impedance in the maximum-output position of the OUTPUT RANGE selector.

Adjustment of the leveled output over a range of up to 20 dB is achieved by the CARRIER LEVEL control, which varies the reference voltage fed to the feedback loop. The uppermost 6 dB of this range is used only in the 10-volt cw mode of operation, and the lowermost 4 dB provides overlap between the 10-dB steps of the attenuator and permits reaching the low-level limit of 0.1 microvolt.

The resistive 10-dB-per-step attenuator includes the input switching required to provide proper impedance characteristics and straight-through operation with zero insertion loss. After an impedance-matching 10-dB input section, the attenuator is a continuous 100-ohm ladder. This provides a 50-ohm output impedance since the output always sees the source and load segments of the ladder connected in parallel. The extremely low vswr of the output impedance (less than 1.02 over the whole frequency range) is due to close control of resistor values and of physical dimensions, as well as of the size and shape of the shield pockets in which the resistors are located. At the output tap, special rotating shield members are used to prevent pickup of stray leakage from the input, which could reduce the accuracy of the attenuator at the extremely high maximum insertion loss of 140 dB. Resistors are aged and checked for stability to ensure long-term accuracy.

The high-level auxiliary output is taken from the monitoring point by way of a 10:1 divider and through a coaxial switch, which isolates the FREQUENCY METER output connector from the input by over 100 dB when the auxiliary output is not required.

Frequency Monitoring

The 0.5-percent direct-calibration frequency accuracy of the 1026 is adequate for most applications; yet some measurements (e.g., those of steep-sided filter characteristics) do require even greater accuracy. The built-in crystal calibrator improves calibration by at least an order of magnitude. At exact multiples of 1 MHz, the frequency

can readily be determined to within 0.01% (the actual crystal frequency is accurate to 0.001%), but practical measurement must include allowances for failure to set to zero beat and for short-term drift. In interpolation between beat points, accuracy is typically better than 0.05%.

Selectivity measurements of narrow-band receivers must sometimes be made directly at the signal frequency rather than at the intermediate frequency. Since in this case the percentage bandwidth is small, it may be necessary to determine individual frequencies to the very high precision possible with a counter. The special switching and shielding provisions associated with the high-level auxiliary FREQUENCY METER output have already been described. As an additional feature, for the user who is annoyed by the noise radiated by some counters, auxiliary contacts on the FREQUENCY CALIBRATOR switch permit automatic quieting of the counter when it is not actually required to count.

The combination of the crystal calibrator and the high-level FREQUENCY METER output makes it possible to use

the signal generator as a heterodyne frequency meter. An external signal applied to the FREQUENCY METER connector is mixed with the signal-generator output in the same detector used for the crystal calibrator function, and resulting beats are amplified and delivered to the BEAT OUTPUT jack. The crystal calibrator provides the accuracy required for many measurements, and the audible monitoring of signal quality often yields information that is completely absent in a counter measurement.

Leveling and Modulation

Leveling of the output rf amplifier is now generally accepted as an essential convenience feature in any modern signal generator. It speeds up the measurement process by eliminating an operator adjustment, and it facilitates scanning of a band to observe frequency response characteristics. Substantial improvement in level stability at any given frequency can be achieved as a useful byproduct of leveling. This amplitude stability, extremely important in precision measurements of insertion loss, is shown in Figure 7. The

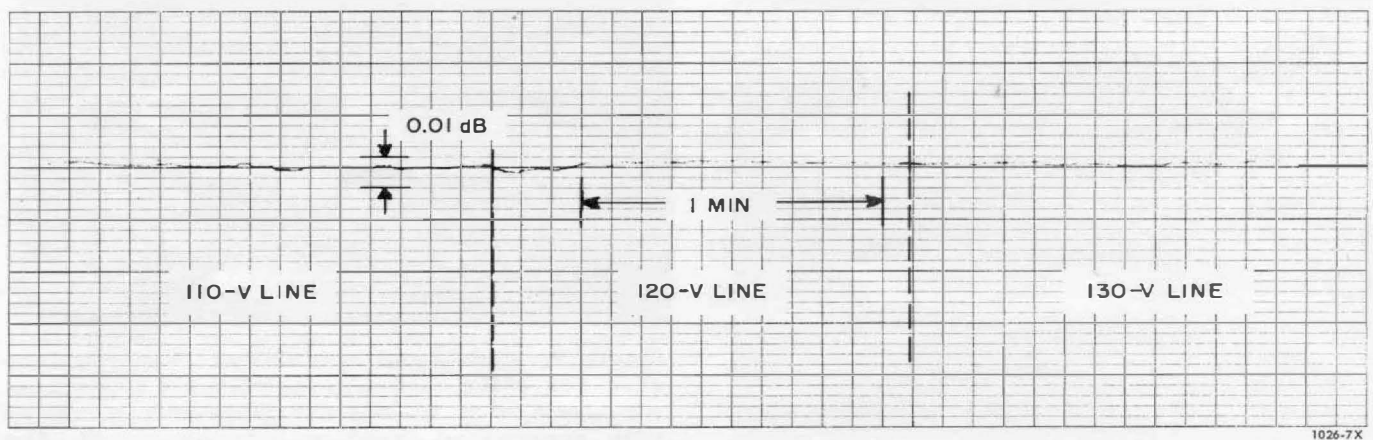
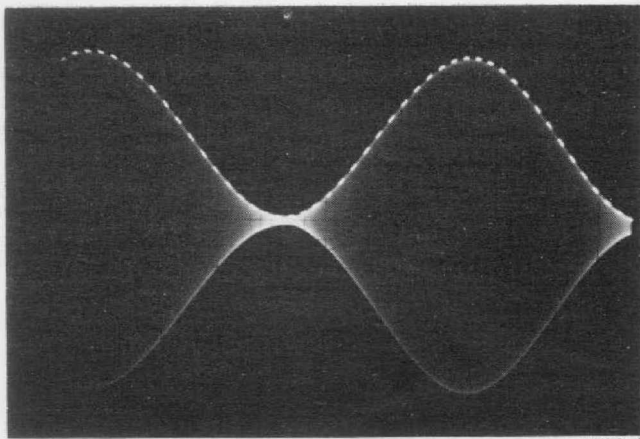

Figure 7. Short-term amplitude stability. The peak amplitude of the envelope of a 400-MHz carrier modulated 95% at 1 kHz, recorded against time with line-voltage steps.



1026-4

Figure 8. Modulation linearity: The envelope of a 400-MHz carrier modulated 95% at 1 kHz is shown with superposed modulation signal. The oscilloscope trace of the 1-kHz modulation signal has been intensity-modulated at a synchronized 30-kHz rate to avoid masking of the modulation envelope.

record of the detected modulation envelope vs time and line-voltage steps illustrates the stability of both carrier level and modulation depth.

The accuracy of leveling depends on the frequency characteristics of the detector used to sense the level changes, on the harmonic content of the signal to be leveled and its effect on the detector response, on the magnitude of level changes that require compensation, on the gain of the compensating loop, and on the stability of the dc reference voltage.

Signal harmonics are often ignored in leveling specifications. Moreover, in any circuit with adequate loop gain, their presence is not betrayed by the carrier level meter. In the 1026, appropriate filters reduce harmonics to at least 30 dB below the carrier level. Leveling performance of the 1026 is shown in Figure 3.

Loop gain cannot be increased indefinitely without loss of stable operation. The relation of gain and phase to

frequency must be carefully controlled when many stages are enclosed in the feedback loop. For cw and audio-modulation operating modes, envelope feedback is used to reduce residual hum modulation and to provide low envelope distortion at high percentages of modulation. The corner frequency of the loop-gain roll-off is 600 Hz, permitting maximum gain for carrier-level stabilization, while still providing substantial negative feedback to reduce modulation envelope distortion in the normal audio range. In Figure 8, the input audio waveform is superposed on the rf envelope of a 400-MHz carrier modulated 95% at 1 kHz.

Particular attention has been paid to stability of the reference voltage and of the frequency and amplitude of the internal 1-kHz oscillator, in order to maximize the usefulness of the generator in precision loss measurements. A portion of the 1-kHz signal is available for synchronization of oscilloscopes or synchronous detectors.

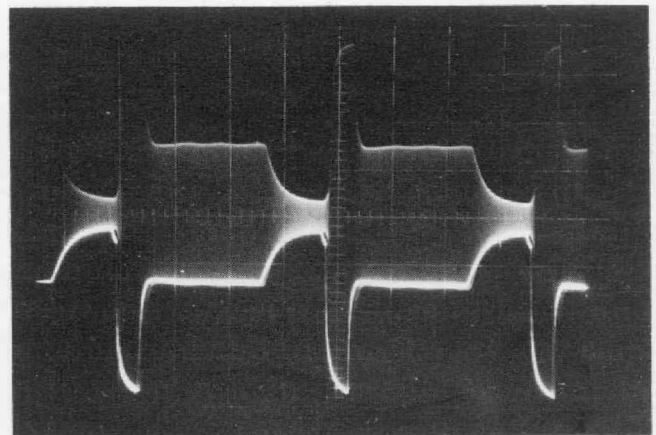

1026-3

Figure 9. Wide-band modulation: The envelope of a 400-MHz carrier modulated by a complex waveform at a 50-kHz repetition rate is shown with superposed input modulation signal. The 2- μ s-duration modulation peak is produced by the negative-going portion of the input signal.

The over-all system amplitude stability shown in Figure 7 includes the effects of the 1-kHz internal oscillator.

The modulator consists of a signal-level comparator followed by a multi-stage error amplifier to provide the necessary gain and power to control the cathode current of the modulated power-amplifier tubes. One input to the comparator is provided by the signal detector after preamplification. The CARRIER LEVEL meter is connected to this input. The other input from the CARRIER LEVEL control consists of dc only for cw operation or dc with audio superposed for internal 1-kHz or external audio modulation. The modulation level is monitored in terms of the audio voltage superposed on the carrier control voltage.

In the WIDE-BAND mode of operation, long-time-constant networks are added to the feedback loop so that it cannot follow modulation-frequency voltages but can still stabilize the carrier operating point on a dc basis. The modulation voltages are then inserted at a

subsequent stage in the loop. A complex wide-band modulation signal and the associated modulation envelope are seen in Figure 9.

In the PULSE mode, the pulses detected in the signal detector are stretched and converted to a dc value

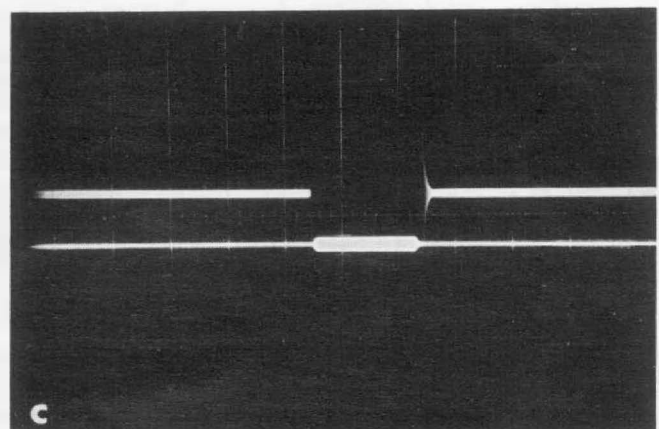
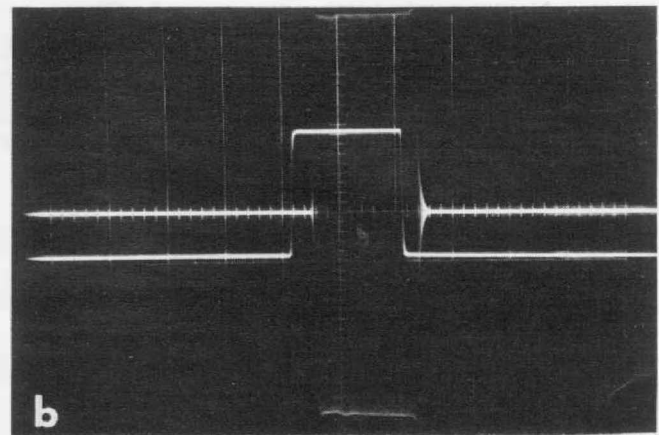
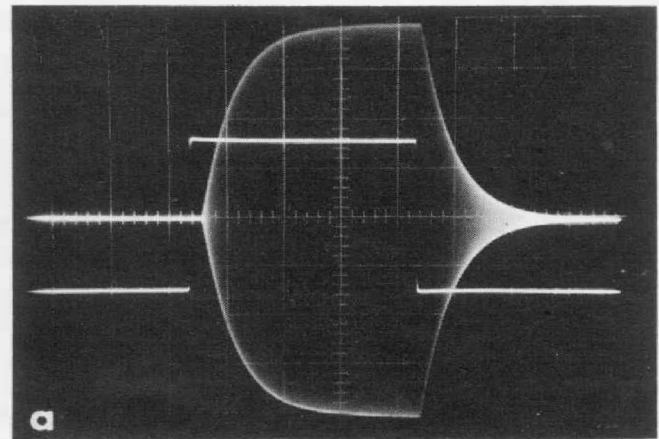

Figure 10. Pulse-modulation characteristics: In (a), the envelope of a 10-MHz carrier modulated by an 8- μ s pulse is shown together with the input pulse. Rise and fall times of 3 μ s and delays of 0.5 μ s are evident from the 2 μ s/cm graticule. In (b), the envelope of a 500-MHz carrier modulated by a 2- μ s pulse is shown together with the input pulse. Rise and fall times of 0.2 μ s and delays of 0.4 μ s are evident from the 1 μ s/cm graticule. In (c), a composite picture shows an on-off ratio in excess of 50 dB for a 500-MHz carrier modulated by a 2- μ s pulse. The upper trace shows the residual signal as a thickening of the base line; the large off-scale deflection during the 2- μ s pulse period causes apparent blanking in the center of the trace. The lower trace shows the same pulse with the output attenuator set for a 50-dB reduction in level. The peak amplitude of the lower trace is greater than the interpulse amplitude of the upper trace, demonstrating an on-off ratio in excess of 50 dB.

1026-2



Gordon McCouch graduated from Harvard University in 1941 and obtained his MA in 1948. After a year with the Radio Research Laboratory he went to England for the office of Scientific Research and Development, later serving as a Technical Observer in continental Europe. From 1945 to 1957 he was with Aircraft Radio

Corporation. Since then he has been a member of the GR Engineering Department; he is now Section Leader responsible for the design of signal generators.

He is a Senior Member of IEEE and is currently a member of the Sections Committee of IEEE.

just before the final power stage of the modulator. A typical pulse-modulation envelope is shown in Figure 10.

Power Supply

In the 1026, power-supply dissipation present in conventional regulated supplies is minimized by a new preregulator that controls the input to the primary of the power transformer (see Figure 11). This preregulation stabilizes the heater voltages of all tubes, thereby contributing to long-life performance, and reduces the swings that the electronic postregulators have to accommodate. The power dissipated in the instrument is only about 90 watts and is almost independent of input line voltage. The power supply operates satisfactorily over the 50-to-60-Hz line-frequency range and can be connected for either 115- or 230-volt operation.

The preregulator, like a conventional electronic regulator, compares an output dc voltage with a reference and amplifies the resultant error voltage.

corresponding to their peak amplitude before they are delivered to the signal-level comparator. Long-time-constant networks are added to the feedback loop in this mode. Thus, operating as a dc amplifier, the loop establishes a clamping level to which input pulses can drive the output amplifier. These input pulses are inserted into the loop

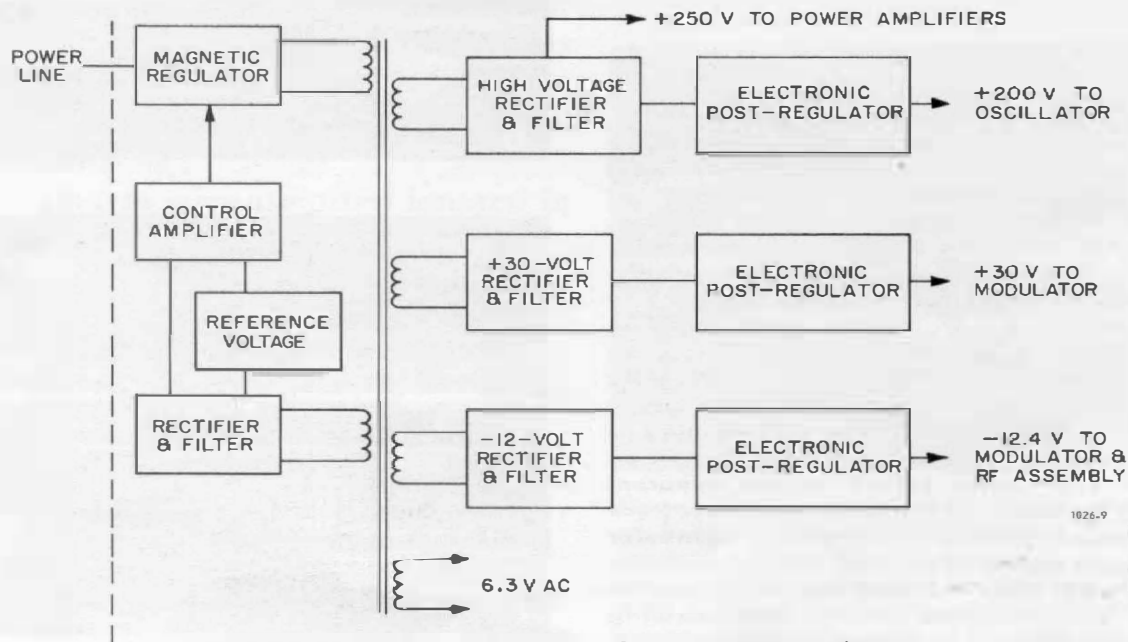

Figure 11. Block diagram of the power supply.

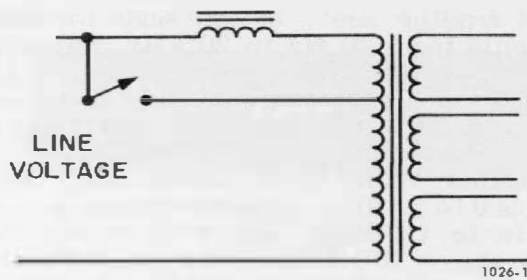

Figure 12. Elementary schematic showing pre-regulator tap-switching scheme.

But, instead of controlling a series loss element, the control voltage operates a magnetic amplifier that switches the input line between high- and low-voltage taps on the power-transformer primary, in such a way that the average output voltage is maintained at the desired value (see Figure 12). Actually, the high-voltage tap is always connected through a series inductor, which saturates and thus has a low drop during the part of the cycle when it carries the line current

to the high-voltage tap. During the remainder of the cycle, it floats across the portion of the transformer between primary taps and carries only magnetizing current. At this time, the line current is transferred to the low-voltage tap through the magnetic-amplifier inductor.

Since only a portion of the transformer primary is switched by this regulator, waveform distortion is not severe, and the peak-to-rms ratio is not grossly altered. Thus good regulation of both ac heater power and dc output is realized.

— G. P. McCouch

ACKNOWLEDGMENTS

The closest collaboration between the author and S. Brown Pulliam has characterized the entire development of the 1026 Signal Generator; the attenuator and the electrical design of the guillotine tuning capacitors were contributed by Andrew P. Lagon.

TENTATIVE SPECIFICATIONS

FREQUENCY

Range: 9.5 to 500 MHz in 6 ranges: 9.5 to 22, 22 to 48, 48 to 108, 108 to 220, 220 to 420, and 400 to 500 MHz.

Manual Control: Main frequency control, spinner knob with 100-division vernier dial (25 turns per range) drives main drum-type dial. Illuminated scale indicates selected range. Parallax-free fiducial mark is adjustable for fine calibration. Scales to 108 MHz are linear. An uncalibrated Δf control spans typically $\pm 0.003\%$ at low end of range to $\pm 0.015\%$ at high end (actual spans may vary 2:1 depending on frequency range).

Scale Characteristics:

| Frequency Range (MHz) | Main Scale Interval | kHz per Vernier Division | Scale Length (in) |
|-----------------------|---------------------|--------------------------|-------------------|
| 9.5-22 | 100 kHz | 5 | 14 1/4 |
| 21.2-49.6 | 200 kHz | 11 | 14 1/4 |
| 47.4-111 | 500 kHz | 25 | 14 1/4 |
| 100-220 | 1.0 MHz | 45-60 | 13 |
| 216-430 | 2.0 MHz | 80-150 | 10 1/2 |
| 400-500 | 2.0 MHz | 150 | 4 |

External Electrical Fine Frequency Control: Applied voltage of ± 20 V dc varies frequency typically $\pm 0.04\%$ at low end of range to $\pm 0.2\%$ at high end (actual variation may differ by 2:1 depending on frequency range).

Calibration Accuracy: $\pm 0.5\%$ direct reading, after initial adjustment of fiducial. With internal crystal calibrator, $\pm 0.01\%$ at 1.0-MHz intervals, typically $\pm 0.05\%$ by interpolation.

Calibration Provisions: Internal crystal frequency, accurate to $\pm 0.001\%$, provides calibration at intervals of 1 and 5 MHz over entire frequency range. Calibration by external counter provided for by output of about 0.1 to 1 V behind 50 Ω . When not needed, this output can be disabled with >100 -dB isolation; external counter can be simultaneously disabled by a contact closure provided to eliminate interference from the counter's internal signals.

Harmonic Output: At least 30 dB below carrier.

RF OUTPUT

Range: CW, 0.1 μ V to 10 V behind 50 Ω , 1/2 W into 50 Ω (-133 to $+27$ dBm); modulated, 0.1 μ V to 5 V behind 50 Ω (-133 to $+21$

dBm). Load $v_{SWR} > 2.0$ may restrict the max output available at some frequencies.

Control: Step attenuator, 140 dB in 10-dB steps, voltage and dBm calibration. Continuous interpolation with metered level control.

Meter Scales: 0.3 to 1.5 V, 1.0 to 5.0 V, and -13 to +1 dBm. Scale extensions (in red), for cw use only, to 10 V and to +7 dBm.

Accuracy: Metering, $\pm 5\%$ to 108 MHz; above 108 MHz, harmonics can add $\pm 3\%$ and rectifier characteristic can add $\pm 2\%$. Attenuator, $\pm 1\%$ (± 0.1 dB) per step; max accumulated error ± 0.5 dB.

RF Interference: Leakage has negligible effect on measurements of receiver sensitivity down to 0.1 μ V.

Leveling: CW output is held at preset level to within $\pm 2\%$ (0.2 dB) up to 108 MHz and to within $\pm 5\%$ (0.5 dB) to 500 MHz as frequency is varied, including effects due to range switching. Effectiveness of leveling under modulated operation is a function of modulation mode and frequency.

Stability: At any given frequency, in cw operation or internal 1-kHz modulation mode, and after 2-hour warmup, output will typically remain constant within ± 0.0025 dB per minute, or ± 0.01 dB over any 15-min period. Also under these conditions, variation due to $\pm 10\%$ line-voltage fluctuation is $< \pm 0.005$ dB.

Effective Generator Impedance (at panel jack): 50 Ω resistive; v_{SWR} is < 1.02 with output attenuator set for 0 dBm or less. At higher outputs, source impedance viewed as Thévenin generator has a $v_{SWR} < 1.2$.

MODULATION

Modes:

Amplitude Modulation is provided in four modes:

1. Internal 1 kHz. Modulation level adjustable 0 to $> 95\%$ and metered to within $\pm 3\%$ of reading $\pm 2\%$ of full scale. Envelope feedback provides leveling and holds distortion to $< 1\%$ at 50% modulation and $< 3\%$ at 80% modulation. Modulating frequency, 1 kHz $\pm 0.5\%$; after 2-hour warmup stable to better than 0.1% over 8-hour period or for line-voltage variations of $\pm 10\%$. 1 kHz signal available at MOD binding posts, about 2.5 V behind 100 k Ω .

2. External Audio. Response flat to dc, down < 3 dB at 20 kHz. Square-wave response 0 to 10 kHz; rise and fall times $< 10 \mu$ s; overshoot $< 10\%$; rampoff negligible. Modulation level is adjustable 0 to $> 95\%$ for dc to 5-kHz input, to $> 50\%$ at 20 kHz, and is metered to within

$\pm 5\%$ of reading $\pm 5\%$ of full scale for sine-wave inputs from 20 Hz to 20 kHz. For 95% modulation < 3 V, peak required into 3 k Ω . Envelope feedback provides leveling and holds distortion at 50% modulation to $< 1\%$ up to 1 kHz, $< 5\%$ up to 10 kHz.

3. External Wide Band. Modulation level adjustable 0 to $> 80\%$. Response flat to ± 3 dB for 50-Hz to 1.5-MHz inputs at carrier frequencies above 108 MHz. Average carrier is leveled and metered, but modulation depth and linearity should be monitored externally. For full modulation, about 0.6 to 3.5 V (depending on carrier frequency) is required into 3 k Ω .

4. External Pulse. Required input pulses, at least 10 V peak, positive going (max 30 V); repetition rate 500 Hz to 150 kHz; duration 1 to 300 μ s (min 3 μ s on 9.5- to 22-MHz range); max 50% duty ratio. Input impedance 3 k Ω . Output pulse, duration within $\pm 0.5 \mu$ s of input; rise and fall times $< 1 \mu$ s each on all ranges but 9.5 to 22 MHz (up to 3 μ s); rampoff $< 5\%$. On-off ratio > 30 dB and at max output setting of attenuator is typically > 40 dB. Peak amplitude of pulses is leveled and metered to within ± 1 dB added to accuracy specified for cw leveling.

Incidental FM (accompanying a-m): < 1 ppm, peak, at 1 kHz, 50% a-m.

Residual FM: < 0.05 ppm, peak.

Residual A-M: At least 70 dB below carrier level in cw, internal 1 kHz and external audio modes.

GENERAL

Power Required: 105 to 125 or 200 to 250 V, 50 to 60 Hz, 90 W.

Terminals: RF and counter outputs are GR874 Coaxial Connectors, recessed and locking; for rapid conversion to other common types, use locking GR874 adaptors. Modulation connection is to front-panel binding posts and rear-panel multiterminal connector. Audio (BEAT) output from front-panel telephone jack. Electrical frequency control is through rear-mounted 12-pin connector.

Accessories Supplied: Type 874-R22LA Patch Cord (GR874 to GR874), phone plug, 12-pin connector plug, CAP-22 power cord, spare fuses, hardware for bench and rack mounting.

Mounting: Rack-bench cabinet.

Dimensions: (width x height x depth): Bench, 19 x 17 $\frac{3}{4}$ x 15 $\frac{1}{4}$ in (485 x 450 x 390 mm); rack, 19 x 17 $\frac{1}{2}$ x 13 in (485 x 445 x 330 mm).

Weight: Net, 96 lb (44 kg); shipping (est), 180 lb (80 kg).

| Catalog Number | Description | Price in USA |
|----------------|-------------------------------------|--------------|
| 1026-9701 | Type 1026 Standard-Signal Generator | \$6500.00 |

THE GUILLOTINE CAPACITOR

The frequency range between 200 and 1000 MHz presents special challenges in the design of wide-range tuned circuits. Cavities become extremely bulky, and their ranges are difficult to extend by bandswitching techniques; operation in both $\lambda/4$ and $3\lambda/4$ modes can extend the tuning range, especially to higher frequencies, as in the GR 1360 signal source, which tunes from 1700 to 4200 MHz. Lumped LC circuits usually end up with larger inductance than is desired in the face of the inevitably significant minimum capacitances established by the active elements required for power generation or amplification. For many years GR has successfully employed the butterfly circuit,¹ an integral LC tuner, to provide tuning ranges up to 5:1 in the frequency

range up to about 1000 MHz, but this circuit does not lend itself readily to major extension of frequency range by bandswitching.

These considerations led to a re-examination of tuning-capacitor design during the development of the 1026 Standard-Signal Generator (see page 3). The result was a new design, a translatory-motion tuning capacitor consisting of a pair of stators and a sliding plunger in place of a rotor (Figure 1). Given this configuration and its sliding action, it could not escape being nicknamed "guillotine." As far as we know, previous efforts to build this type of capacitor have never been carried to successful commercial realization, presumably because of the mechanical problems inherent in building a suitable carriage to support the plunger and in driving it.

¹E. Karplus, "The Butterfly Circuit," *General Radio Experimenter*, October 1944.

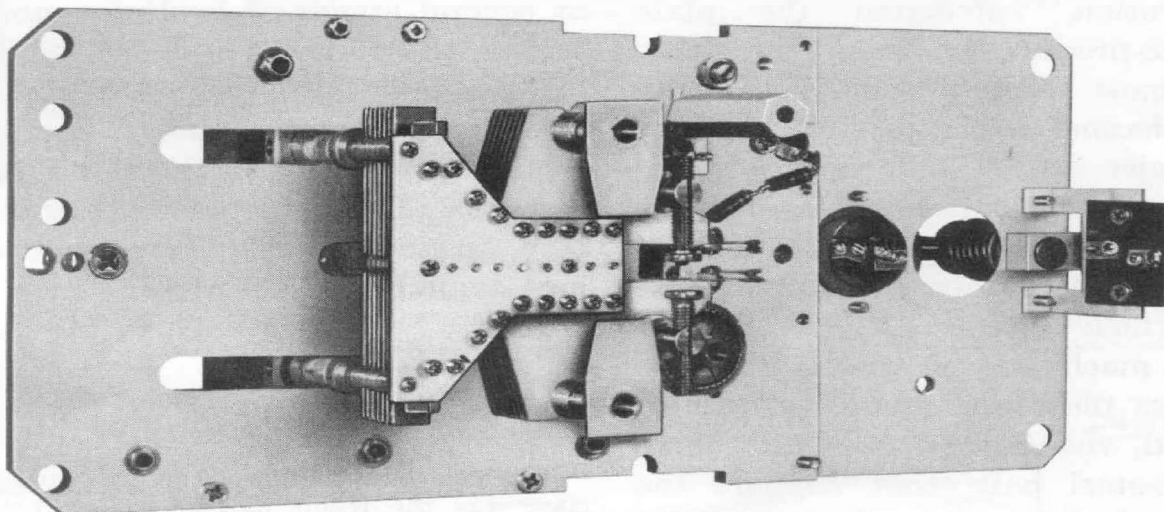

Figure 1. The guillotine capacitor, as used in the 1026 Standard-Signal Generator.

Nevertheless, our preliminary work showed that we could build a one-band oscillator to tune to at least 700 MHz with the guillotine, compared with a top frequency of about 500 MHz with a rotary capacitor. This was the margin we sought in order to design for a 500-MHz top frequency in our new signal generator. The margin was needed to permit the added inductance required for bandswitching coil contacts and to allow for the trimmers necessary to provide tracking of oscillator and amplifier circuits without the need for operator trimmer adjustment. Furthermore, the plates could be shaped to provide a linear relation of frequency to dial indication without intermediate cams for law conversion, and the plates could be supported at their extremities to minimize microphonics. These advantages of the guillotine design persuaded us to tackle the associated mechanical problems.

The guillotine is a balanced structure suitable for both single-ended-oscillator and push-pull-amplifier service with but minor differences. Andrew P. Lagon, of our engineering staff, who suggested that we use the guillotine configuration, calculated the plate shapes to produce the linear tuning law, which most users find attractive because channel allocations within any one service are of uniform width and spacing. Four ceramic rods of high-strength alumina support the pair of stators on a sturdy aluminum base plate, which has been stabilized prior to final machining of critical surfaces. The base plate also carries a pair of hardened, vee-grooved rails with three stainless-steel balls that support the plunger carriage. One of the rails is spring-loaded to eliminate vertical and

horizontal play in the carriage. The carriage is coupled to a rack, also supported by the base plate. The plunger and stators are soldered assemblies of precision-tolerance flat plates and grooved spacer rods.

A reasonably large air gap (0.022 inch) and careful soldering to minimize plate distortion make possible very uniform capacitance characteristics from one unit to the next. Nevertheless, the very tight tracking requirements require adjustment of each capacitor to a predetermined schedule using a segmented top plate on the plunger. Trimming for tube-capacitance variations is accomplished by an auxiliary balanced capacitor whose stator plates are supported directly by the main guillotine stator support rods. In order to minimize connection inductance, the tube plate connectors are integral with the guillotine, and the spring contacts that mate with the coil turret contacts are supported at the narrow end of the stators.

The stability and reproducibility required of the capacitors for successful application in the 1026 Signal Generator were verified by extensive tests at several stages of evolution and on substantial numbers of capacitors built for the first lot of signal generators. This low-inductance design results in such good tracking of the three tuned stages in the new signal generator that true single-dial frequency control is now available to 500 MHz.

— G. P. McCouch

ACKNOWLEDGMENTS

The successful design of the guillotine capacitor was the result of cooperation between Andrew Lagon, Richard Mortenson, David Foss, and the author.



Figure 1. (left to right) Types 874-WO and -WOL Open-Circuit Terminations and Types 874-WN and -WNL Short-Circuit Terminations.

NEW GR874 TERMINATIONS

In coaxial measurements, it is often necessary to set up a short or open circuit at a specific point in a coaxial line. How accurately that point, called the reference plane, is known is one of the most important characteristics of a short- or open-circuit termination. The GR874 short- and open-circuit terminations (Figure 1) have been redesigned to establish the reference plane more accurately and with less

variation with frequency. Locking versions have also been added.

The objective is to place the reference plane exactly at the front face of the support bead of the GR874 connector on the unknown under test (see Figure 2). How well this objective has been met is clearly shown in Figure 3, which compares the reference-plane deviations of the old and new open-circuit terminations.

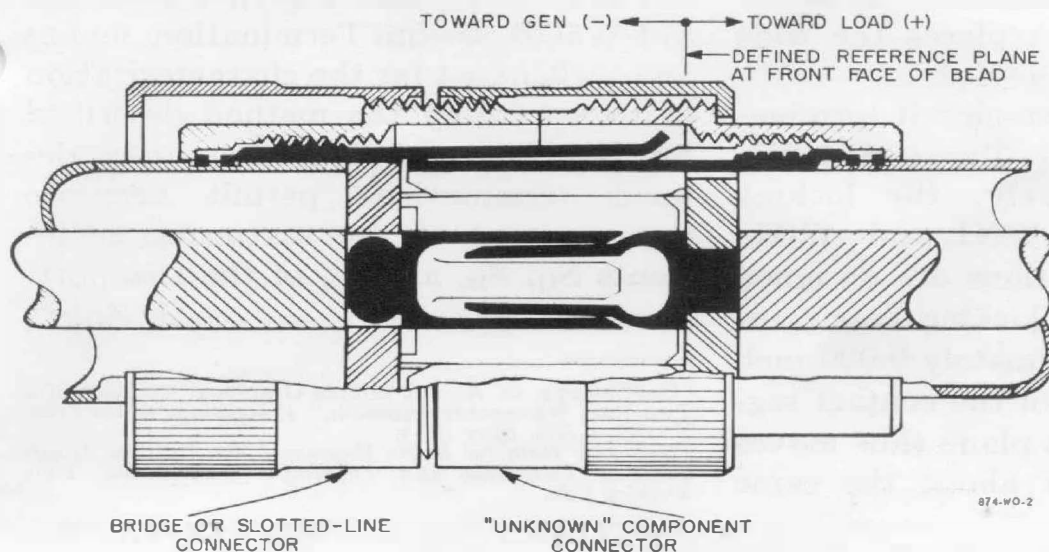
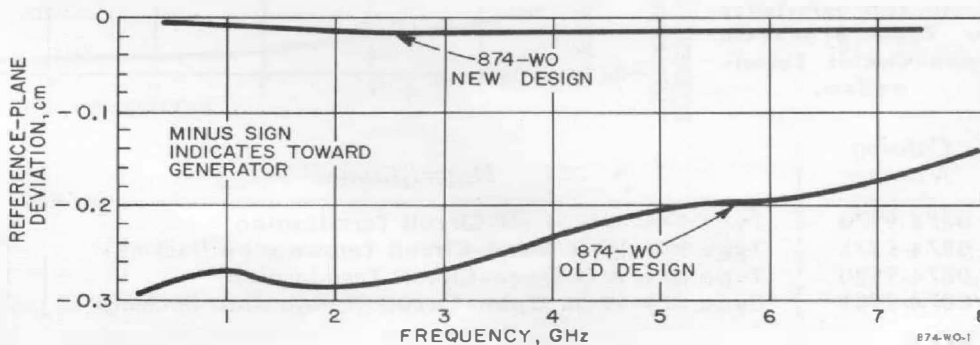

Figure 2. Cross-section of mated GR874 connectors defining reference plane.

Figure 3. Typical reference-plane-deviation vs frequency for old and new Type 874-WO Open-Circuit Terminations.



GENERAL RADIO COMPANY

WEST CONCORD, MASSACHUSETTS 01781

In the open-circuit termination, the key to the improved performance is a built-in cylinder made of high-density polyethylene. This cylinder both provides electrical lengthening and compensates for errors in characteristic impedance.

In the redesigned short-circuit termination, a solid disk replaces the wide strip as the shorting device.

The short- and open-circuit terminations are designated TYPES 874-WN and -WO, respectively; the locking versions are the 874-WNL and -WOL. The locking terminations are designed so that the mating locking connector is disengaged approximately 0.020 inch to prevent jamming of the contact segments. The reference plane thus moves toward the load by about the same

amount. Reference-plane characteristics for the 874-WOL appear in Figure 4.

Applications

Beyond the usual applications for these terminations, the combination of 874-WN and -WO, together with the 874-W5OB 50-ohm Termination, makes an excellent set for the characterization of two-ports by the method described by DesChamps^{1,2}. The accurately defined terminations permit accurate measurement of the scattering coefficients S_{11} , S_{12} , and S_{22} of the two-port.

— J. ZORZY

¹ DesChamps, G. A., "A Simple Graphical Analysis of a Two-Port Waveguide Junction," *Proceedings of the IRE*, No. 42, p 859, May 1954.
² *Reference Data for Radio Engineers*, 4th Edition, International Telephone and Telegraph Corporation, New York, p 649.

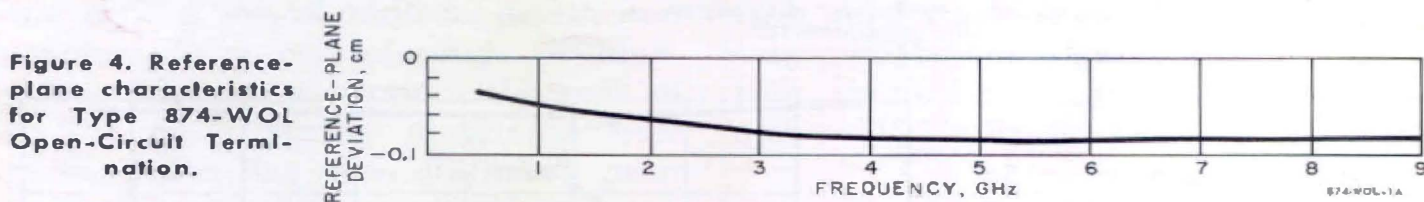

Figure 4. Reference-plane characteristics for Type 874-WOL Open-Circuit Termination.

| Catalog Number | Description | Net Weight | Price in USA |
|----------------|--|--------------|--------------|
| 0874-9970 | Type 874-WN Short-Circuit Termination | 1 oz (30 g) | \$4.50 |
| 0874-9971 | Type 874-WNL Short-Circuit Termination (locking) | 1½ oz (45 g) | 5.75 |
| 0874-9980 | Type 874-WO Open-Circuit Termination | 1 oz (30 g) | 4.00 |
| 0874-9981 | Type 874-WOL Open-Circuit Termination (locking) | 1½ oz (45 g) | 5.25 |